

The Wichita CAB Copper Alloy Brakes are pneumatically actuated water cooled brakes designed for use in constantly slipping applications. The brake has a high power rating within a reduced envelope size for original equipment and upgrading of existing plant.

Applications

The Copper Alloy Brake benefits various tension control and continuous slipping applications in :

- Paper, Film & Foil Industry : Unwind stands on laminators, coaters, winders and slitter/rewinders.
- Steel & non-ferrous strip industry : Decoilers & roller tension units.
- Marine industry : Anchor handling, cable laying and towing winches.
- Testing industry : Dynamometers for gear reducers, agricultural tractors, large vehicles and mining machinery.



Benefits

- Four sizes in either one or two plate models ensure the most suitable brake selection for the application.
- Ease of installation. A novel design of spiral water flow allows better flow integrity within the water jacket. This enables brake mounting with the water connections in any direction; from the top, bottom or side, giving additional flexibility in machine layout and design. The water inlet and outlet connections are located in one area, which reduces the space envelope of the brake. For brakes to be mounted through shaft, the centre of the front cover will be machined out.
- Ease of maintenance. The visual wear indication allows easy wear verification without touching the brake, saving on down time and facilitates better scheduled maintenance. No wear adjustment needed, because the long stroke piston allows for full wear life of the friction material. The removal of just four cap screws in the front of the brake is all that is required to disassemble the brake. After removal of the front cover, all the internal parts slide out. The water jackets slide on four substantial pins and the rotating drive disc slides on gear teeth.

- Enclosed for dust protection. The sliding covers together with a solid cover plate on the other side of the brake effectively enclose the brake making it physically safe from foreign objects. The covers also make it more suitable for clean room environments as they effectively contain any friction dust.
- Multi-range torque selection. Although the standard brake has a single annular piston there are optional multiple piston actuators available for multi-range facility.

This allows optimum torque selection, giving increased machine flexibility for

higher productivity.

- The air inlet is positioned at the side of the cylinder so that the air supply pipe is close to the face of the machine giving better protection and aesthetics.

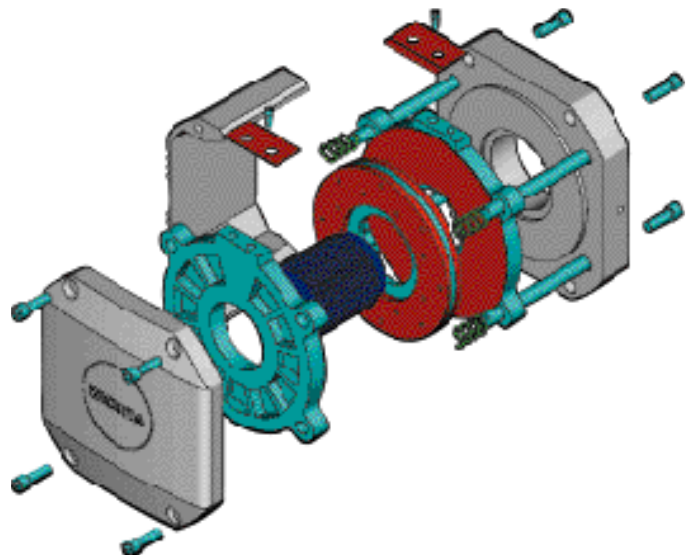

Performance

Model	Dynamic slip torque		Heat transfer capacity	Max speed	Inertia mr ² Hub & drive plate	Weight		Water flow	Piston displacement volume	
	@ 0.2 bar	@ 5.5 bar				Total brake	Hub & drive plate		new	worn
	Nm	Nm	kW	rpm	kgm ²	kg	kg	L/min	cm ³	cm ³
CAB 123	20	380	12.5	3150		32	7	7	67	405
CAB 223	40	760	25	3150		50	17	13	67	405
CAB 131	40	1050	25	2250	0.065	38	9	13	134	810
CAB 231/MR 5	20	525	50	2250	0.135	59	21	26		
CAB 231/MR 10	40	1050	50	2250	0.135	59	21	26		
CAB 231	80	2100	50	2250	0.135	59	21	26	134	810
CAB 145	125	3300	50	1590	0.3	123	22.5	26	297	2385
CAB 245/MR 5	62	1650	100	1590	0.62	210	52	52		
CAB 245/MR 10	125	3300	100	1590	0.62	210	52	52		
CAB 245	250	6600	100	1590	0.62	210	52	52	297	2385
CAB 159	200	9800	100	1120	1.6	258	44	52	620	4965
CAB 259/MR 5	100	4900	200	1120	3.3	380	85	102		
CAB 259/MR 10	200	9800	200	1120	3.3	380	85	102		
CAB 259	400	19600	200	1120	3.3	380	85	102	620	4965

Water inlet temperature 10° C min. - 50° C max. Max temperature rise across brake = 25° C. If a lower minimum torque is required please consult Wichita.

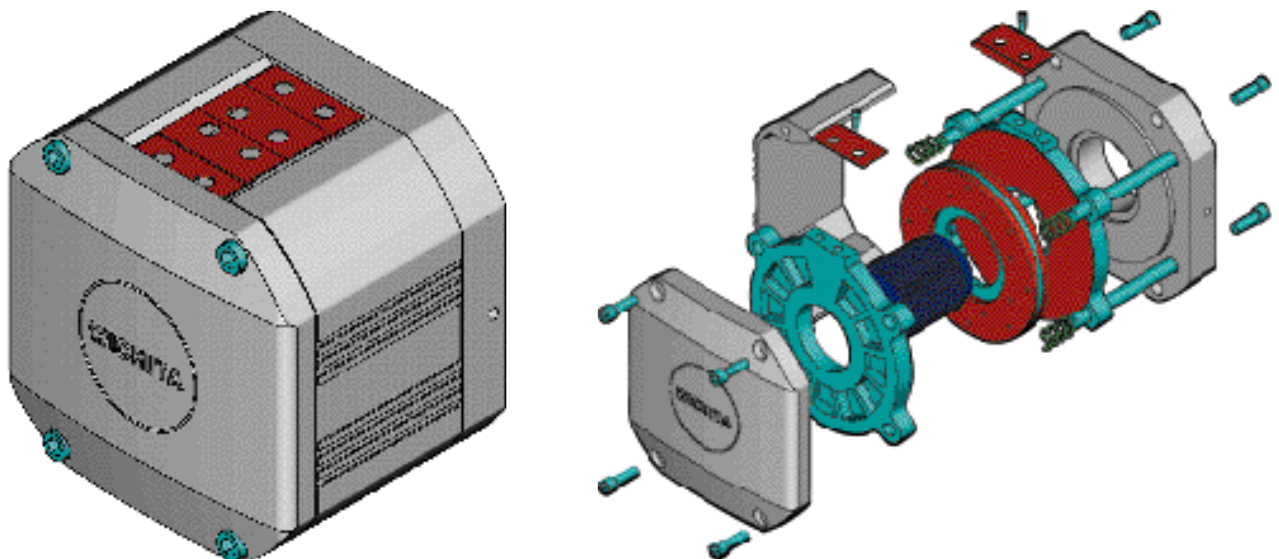

Selection Guide – Service Conditions

- Torque rating** : Dynamic torque ratings may be used in selection for tension control applications.
 Service factors vary for more arduous applications, but as a general guide, use 75% of brake torque. MR – Multi Range versions of all sizes available. Maximum torque with full complement of MR pistons is approximately 50% of the 5.5 bar rating of the regular brake.
- Air pressure** : Torque is directly proportional to air pressure.
- Heat transfer** : The heat ratings stated are for continuous running conditions.
- High speed** : For advice on speeds in excess of those specified above, please contact your Wichita engineer.

Dimensions

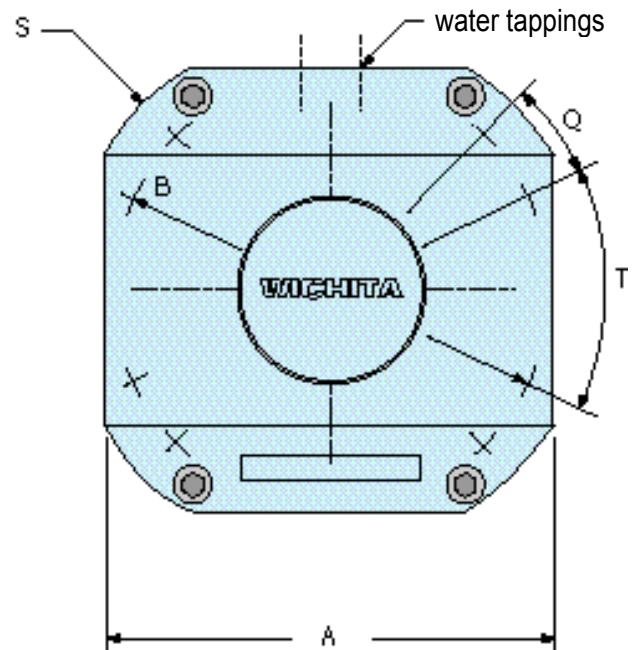
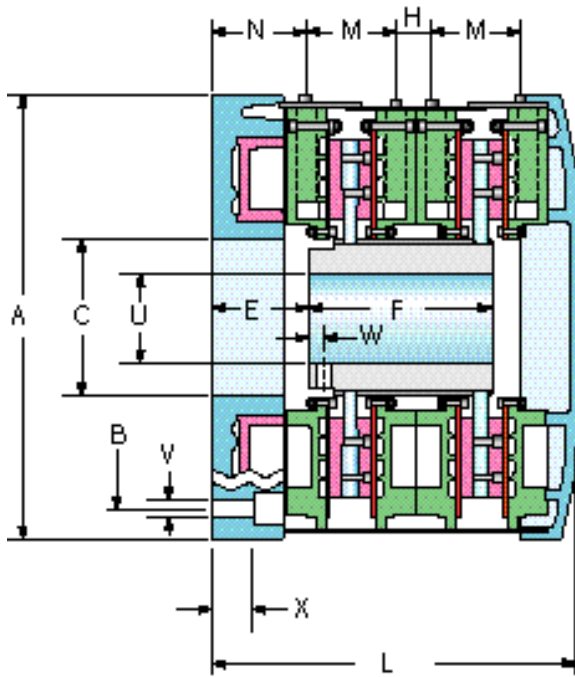

Model	A	B	C	E	F	H	L	M	N	Q	S	T	U1	U2	V	W	X	
	mm	mm	mm*	mm	mm	mm	mm	mm	mm	deg	mm	deg	min	max	mm	qty	mm	mm
CAB 123	230	225	85	78	51	-	193	71	73.5		276	60	15	40	9	4	6	50
CAB 223	230	225	85	78	150	27	291	71	73.5		276	60	15	40	9	4	6	50
CAB 131	310	280	120	76	55	-	200	73	74	30	370	60	25	75	14	8	12	48
CAB 231	310	280	120	76	152	27	300	73	74	30	370	60	25	75	14	8	12	48
CAB 145	450	445	162	80	72	-	238	89	92	20	528	50	35	100	18	8	16	50
CAB 245	450	445	162	90	180	35	362	89	92	20	528	50	35	100	18	8	16	50
CAB 159	590	560	230	90	130	-	296	100	114	30	710	60	50	150	18	8	16	64
CAB 259	590	560	230	90	250	40	438	100	114	30	710	60	50	150	18	8	16	64

* -0.0/+0.1 mm

DIMENSIONS: Certified drawings showing exact dimensions are sent with every order acknowledgement and these should always be obtained before finalising any design details

Water hose connections

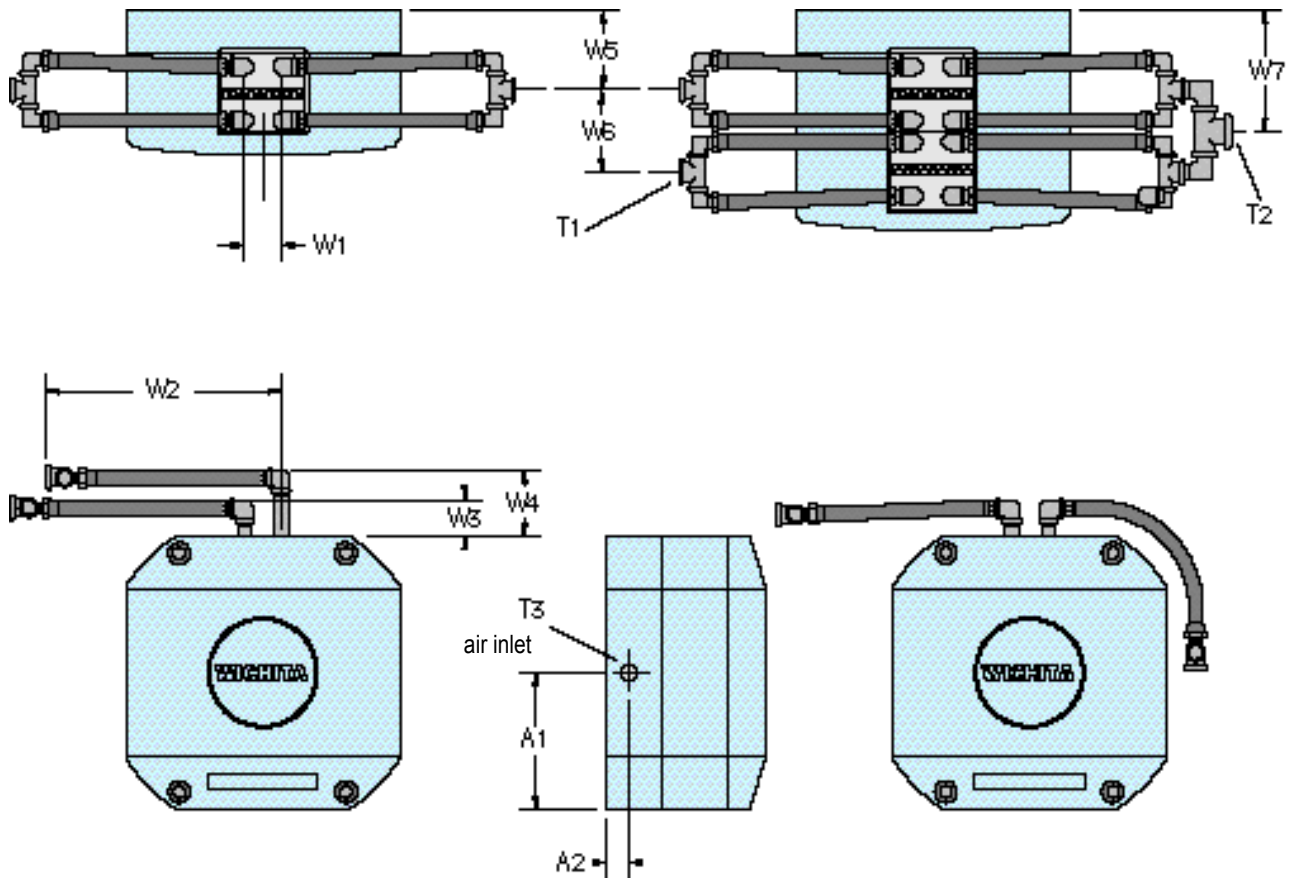

Model	W1	W2	W3	W4	W5	W6	W7	A1	A2	T1	T2	T3
	mm	mm	mm	mm	mm	mm	mm	mm	mm	BSPT	BSPT	BSP
CAB 123	44	325	60	110	130	140	200	115	20	1/2	3/4	3/8
CAB 223	44	325	60	110	130	140	200	115	20	1/2	3/4	3/8
CAB 131	44	445	50	100	110	-	-	155	20	1/2	3/4	3/8
CAB 231	44	445	50	100	110	100	160	155	20	1/2	3/4	3/8
CAB 145	60	445	60	110	130	-	-	225	20	3/4	1	3/8
CAB 245	60	445	60	110	130	135	198	225	20	3/4	1	3/8
CAB 159	70	445	60	110	165	-	-	295	30	3/4	1	1/2
CAB 259	70	445	60	110	165	140	235	295	30	3/4	1	1/2

DIMENSIONS: Certified drawings showing exact dimensions are sent with every order acknowledgement and these should always be obtained before finalising any design details